

Incline/horizontal CONVEYOR

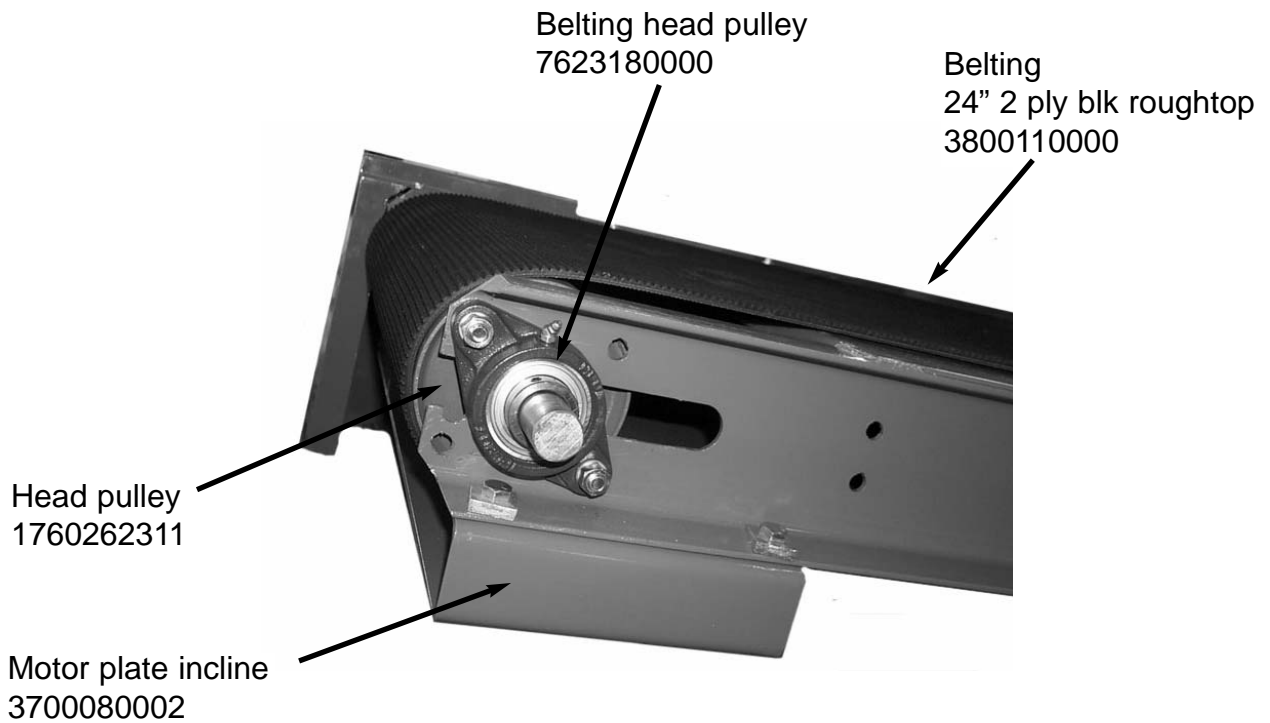

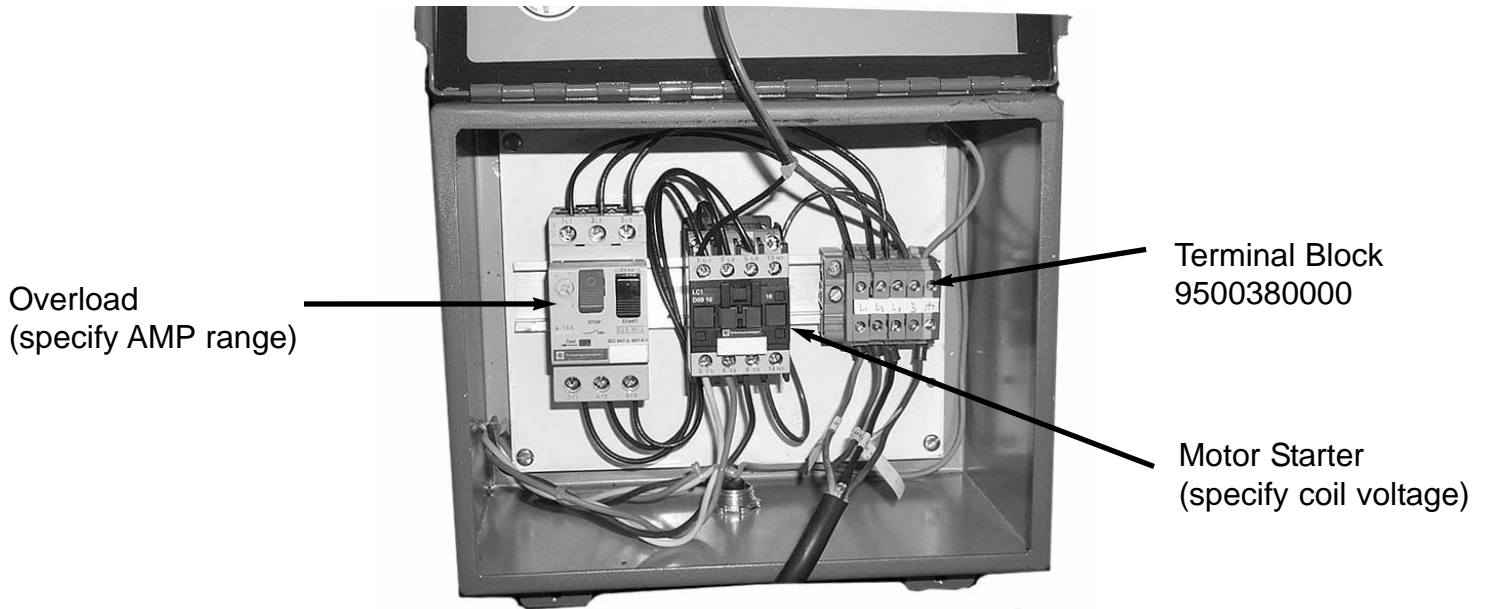
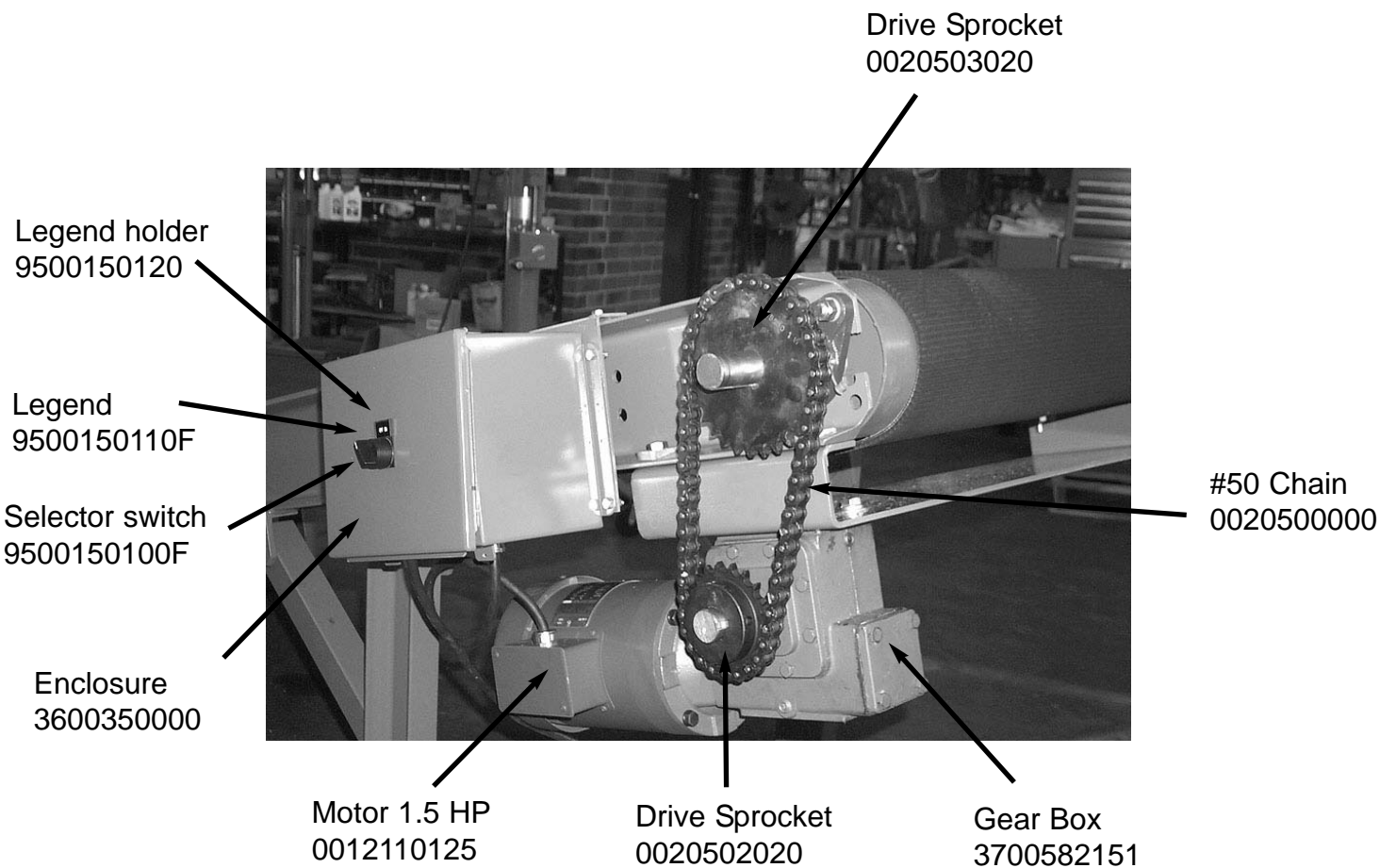
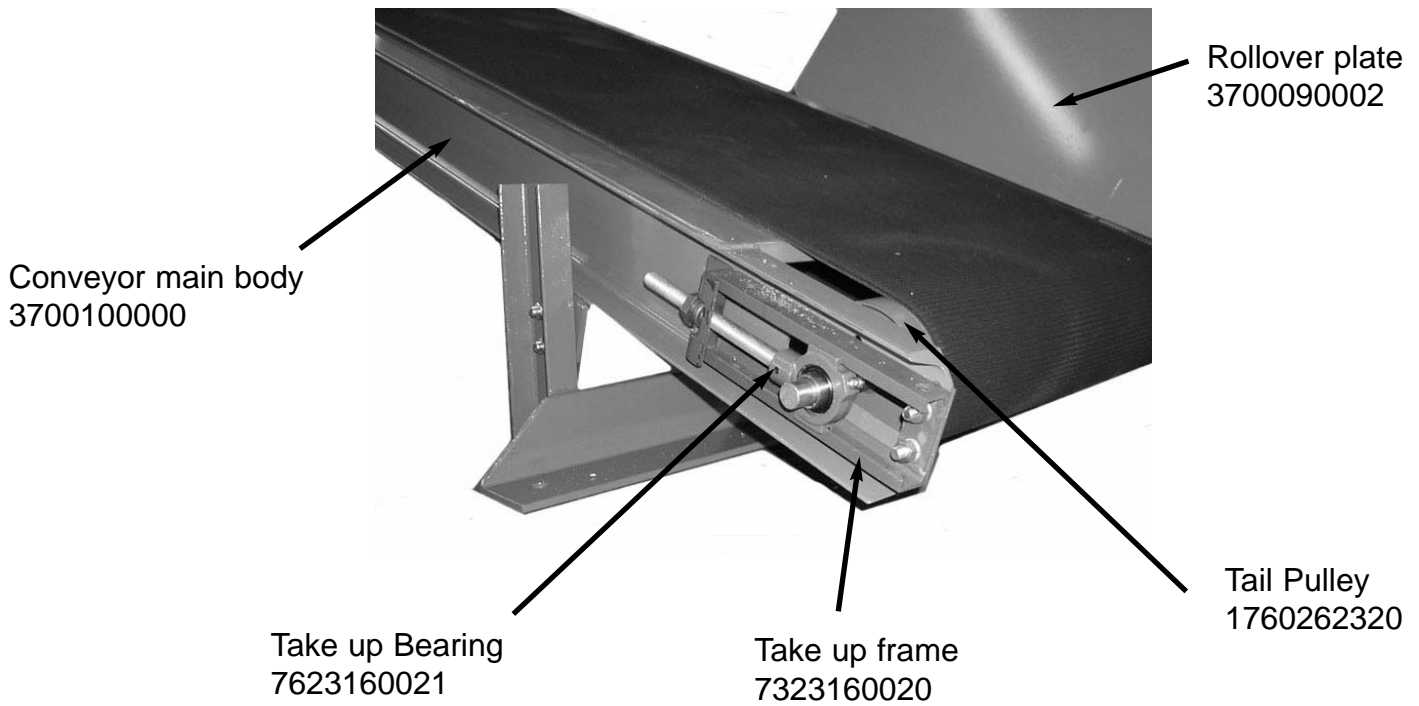

INCLINE CONVEYOR PARTS LIST

PART #	DESCRIPTION	CODE	QTY.
0012110125	Motor - 1.5 HP		1
0012113021	Mtr 113021.00 1.5 HP 3 ph 56c		
0020502020	Sprocket 50 BS 20 x 1.25		
0021913010	Sprocket 50 BS 30 x 1		
1760262311	Head Pulley		1
1760262320	Tail Pulley		1
3600350000	Enclosure		1
3700010002	Conveyor end rail 2 ft slider bed		
3700010004	Rails 4 ft head & tail		
3700010006	Plate reinforcement SS		
3700080002	Motor Plate Incline		1
3700090002	Rollover Plate		1
3700090012	Leg, set, tall 10' incline		
3700100000	Conveyor Main Body		1
3700560441	Connector Body	N	1
3700582151	Gear Box		
3800110000	Belting - 24" 2 Ply Blk Roughtop	R	Varies
3800110020	Belting V cleat	R	
5022750001	Belt lacing 36" SS		
5022750004	Belt Lacing	R	1
7623160020	Take up Frame	R	2
7623160021	Take up Bearing	R	2
7623180000	Bearing - Head Pulley	R	2
9500150120	Legend Holder		1
9500380000	Terminal Block		6
0020500000	#50 Chain	R	3
0020501000	Master Link for #50 Chain	R	1
9500150070F	Contact Block	R	1
9500150100F	Selector Switch	R	1
9500150110F	Legend		1
17GV2ME08	Starter, MMP 2.5-4 amps		

INCLINE CONVEYOR PARTS LIST

17LC1D09F7	Contactora TE 110 V Coil 9A 1 NO		
17SDS1	Bushing SDSX 1.25		

R = recommended spare parts