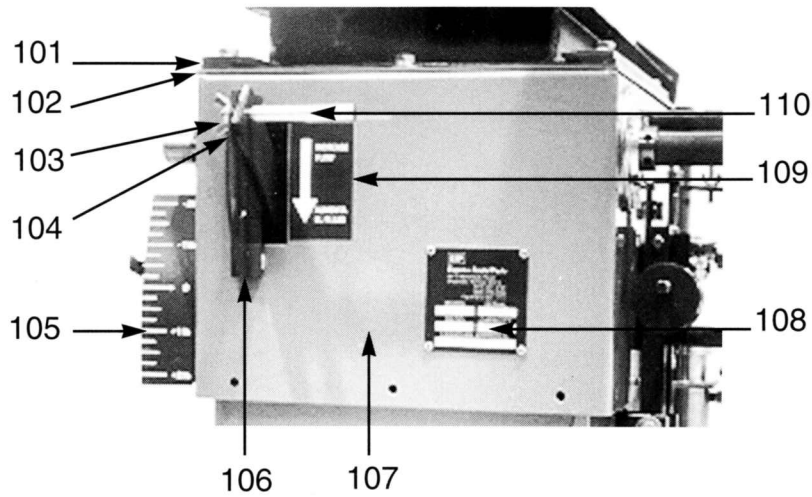
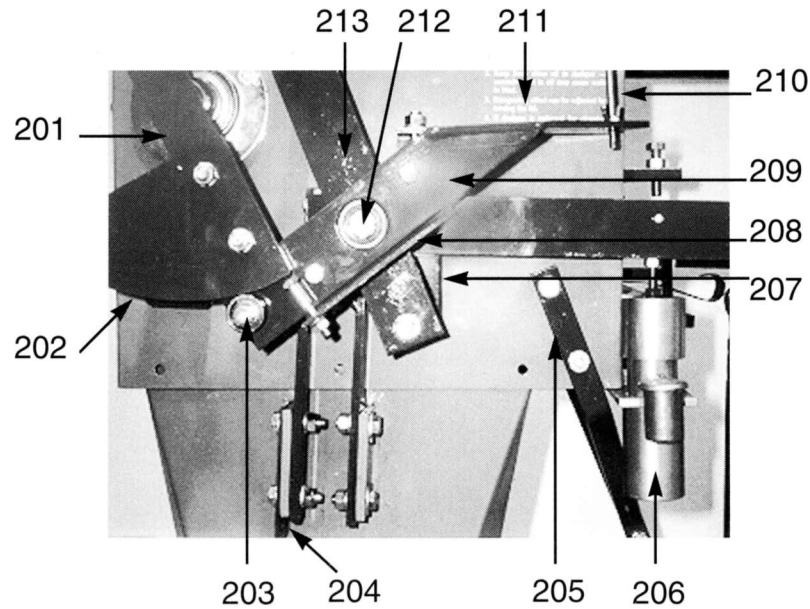

FIGURE 1



INDEX #	PART#	DESCRIPTION	#USED
101	0379823601	Slide Bar	2
102	0379833601	Slide Bar Spacer	2
103	4425950000	Wing Nut	1
104	4425120000	Washer, Special	1
105	7675400001	Decal LB	1
	7675400002	Decal KG	1
106	0418183501	Plate, Regulating Slide	1
107	5424250001	Housing	1
108	9300030000	Nameplate	1
109	7675400003	Decal Flow	1
110	0418176601	Handle, Regulating Slide	1

FIGURE 2



INDEX#	PART#	DESCRIPTION	#USED
201	5424260001	Handle Gate	1
202	0423757001	Knife Edge	*1
203	7055550000	Bearing Knife Edge	*1
204	0398253501	Shipping Clip	2
205	5460190001	Bracket Sway Control	2
206	6000470001	Dashpot Assembly	*1
207	5460160001	Middle Bearing Bracket	2
208	5460230002	Bracket Tr. Arm Bearing	*1
209	5460230001	Trigger Arm	1
210	4743440000	Screw Trigger Trip	*1
211	9300040000	Dashpot Instructions	1
212	7055000000	Bearing Trigger Arm	*1
213	0423793601	Bracket, Trigger Arm Mt.1	
	not shown		
	0034053614	Spacer, Upper	1
	0034053626	Spacer, Lower	1

*Indicates items recommended for spares

FIGURE 3

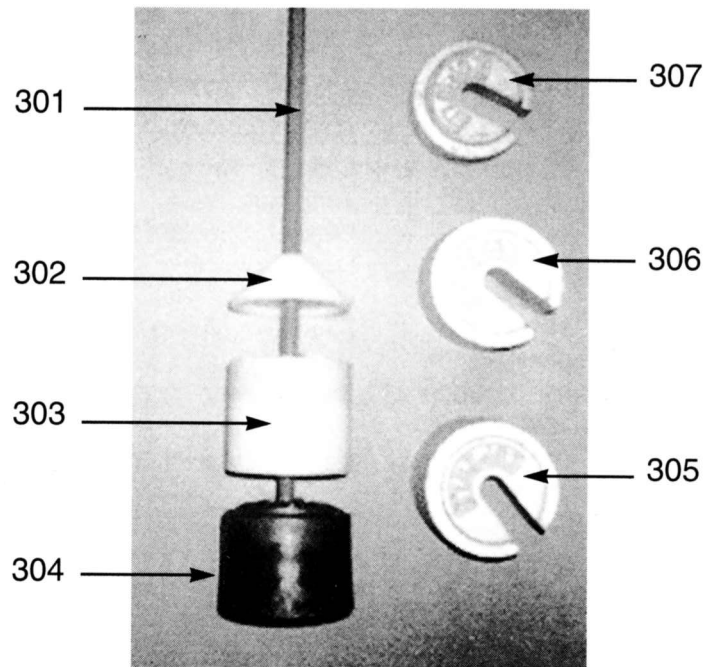

INDEX#	PART#	DESCRIPTION	#USED
301	5447930001	Weight Rod	1
302	9250400000	Weight Box Cover	1
303	9267080000	Weight Box	1
not shown	0372813501	Weight Box Lid	1
304		Weight (option for AO scale only)	1
305	6011400005	25 LB. weight	4
306	6011400002	10 LB. weight	1
307	6011400001	5 LB. weight	1
	6011400026	full set of LB. weights	1
	6011500005	10 KG. weight	4
	6011500002	5 KG. weight	1
	6011500001	2.5 KG. weight	1
	6011500018	full set of KG weights	1

FIGURE 4

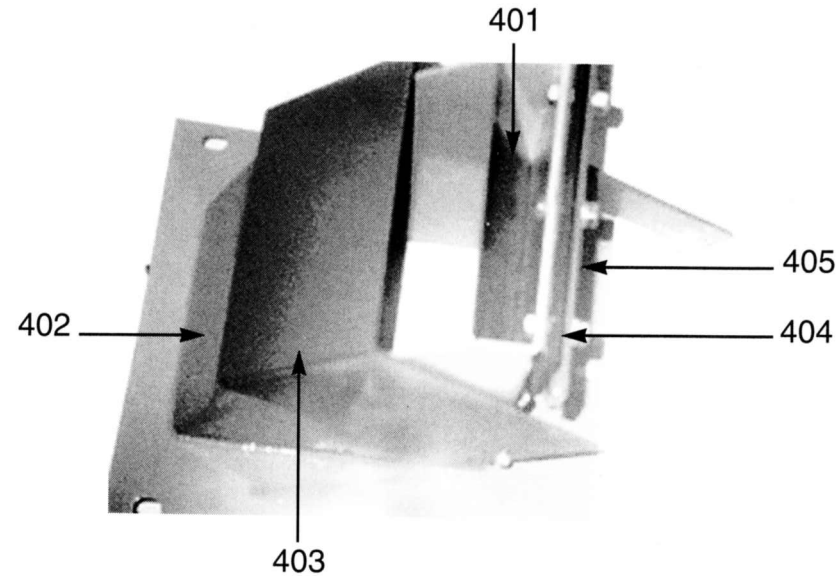

INDEX#	PART#	DESCRIPTION	#USED
401	0467603501	Restrictor Plate	1
402	5418150001	Chute Top	1
403	5418220001	Regulating Slide	1
404	0024257910	Seal Chute	*1
405	0379943601	Gate Stop Bar	1
not shown	0024257911	Plate Seal	1
not shown	5423910001	Chute Gate	1

**Indicates items recommended for spares*

FIGURE 5

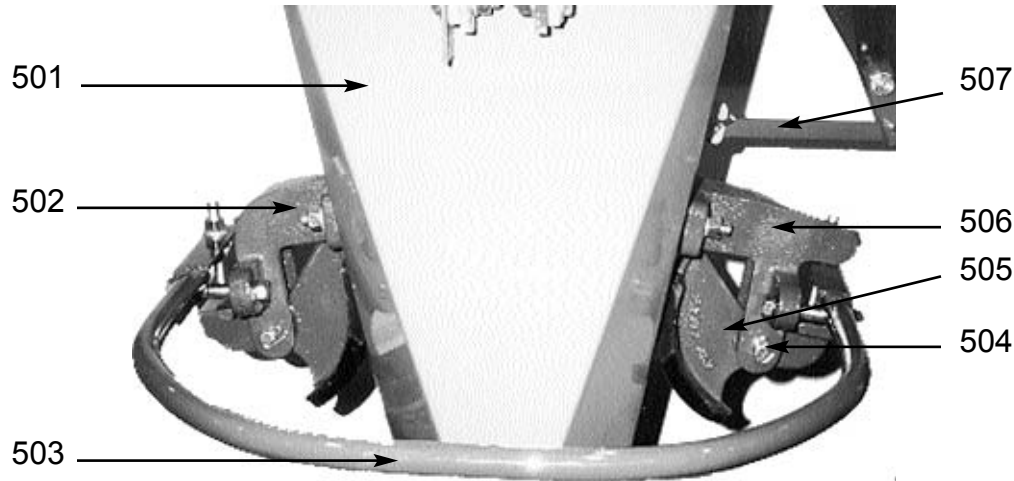
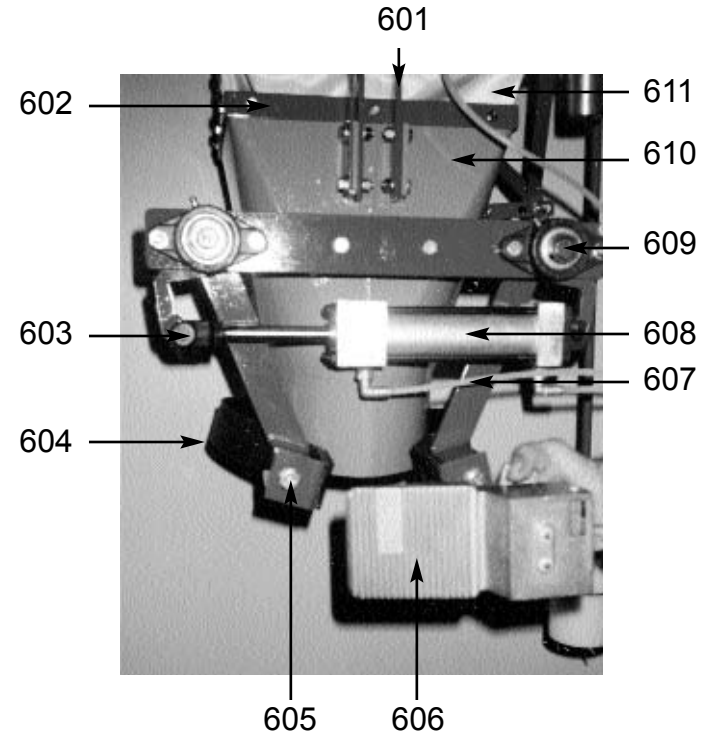

FIGURE 6



INDEX#	PART#	DESCRIPTION	#USED
501	5479500001	Spout - 32"	1
	5419900001	Spout - 25"	1
	5419910001	Spout - 17"	1
502	0479350101	Bracket Bagholder Front	1
503	5460220007	Handle Release - GB32	1
	5460220003	Handle Release - GB25	1
504	4496600000	Pin Fulcrum	2
505	5363180001	Bag Clamp (includes pin)	2
506	0479360101	Bracket Bagholder Rear	1
507	0423943601	Sway Link	1

*Indicates items recommended for spares

INDEX#	PART#	DESCRIPTION	#USED
601	5454480002	H Bracket	2
602	0447973601	Bar Dust Skirt	8
603	8333260002	Clevis	1
604	3799990000	Bag Clamps	*2
605	5448200004	L Bracket	4
606	8953050002	Valve Foot	1
607	8282504444	Airline	*30ft.
608	8333260000	Cylinder Spout	1
609	7623140002	Bearing	4
610		Spout AO 31	1
611	7791780000	Dust Skirt	*1
not shown	3770330040	FR	1
not shown	8282509999	Vent	*1

FIGURE 7

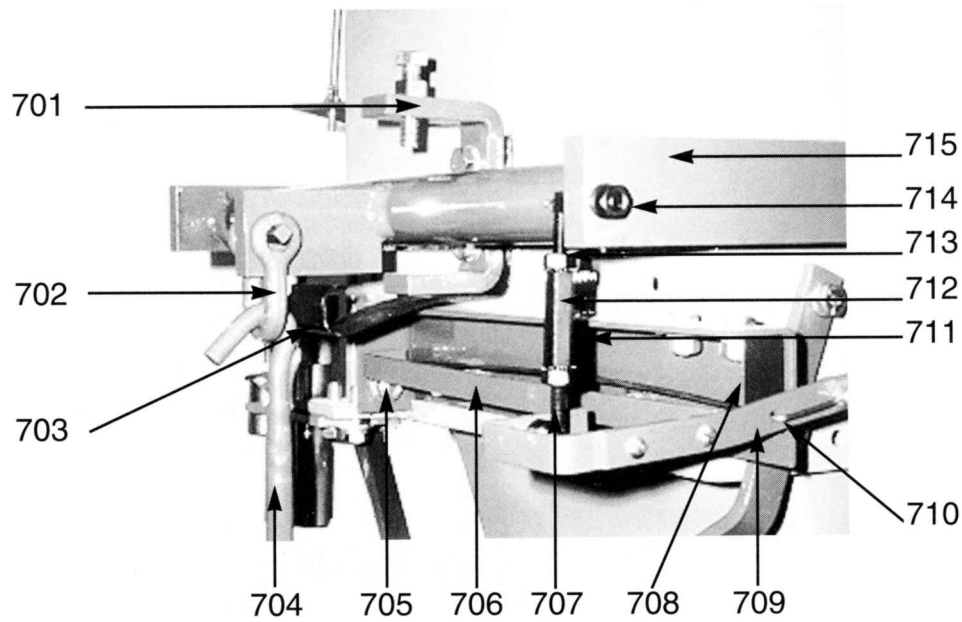

INDEX #	PART #	DESCRIPTION	#USED
701	5460180001	Bracket Beam Stop	1
702	0015480000	Clevis	1
703	7811270000	Compensation Spring	*1
704	5447930001	Weight Rod	1
705	0379725501	Torsion Adjust Bolt	1
706	0444455501	Bar Bearing	1
707	0444395501	Pushrod RH	1
709	0423965501	Pointer	1
710	0379715501	Torsion Rod	*1
711	0444425501	Turnbuckle Ass'y.	*1
712	0444405501	Turnbuckle	1
713	0444385501	Pushrod LH	1
714	0444415501	Pushrod Pin	2
715	6000420000	Main Beam	1
not shown	0423995501	Angle Support	1

*Indicates items recommended for spares

FIGURE 8

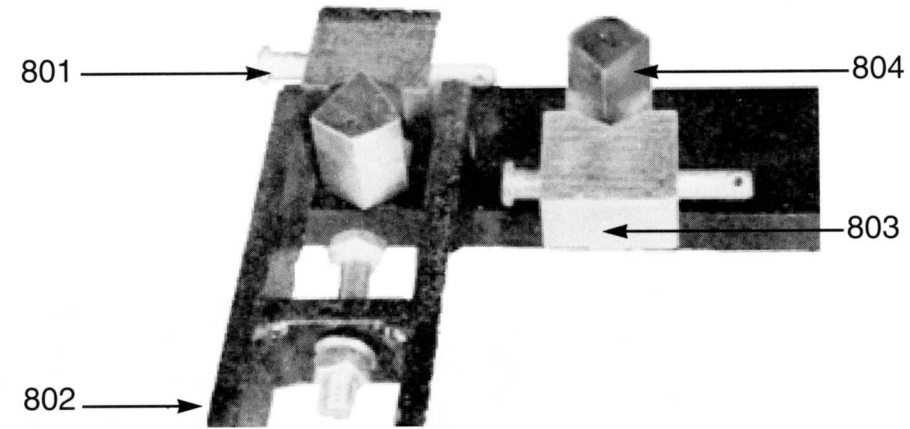

INDEX#	PART#	DESCRIPTION	#USED
801	0381156601	Pin Clevis	4
802	5454480001	Supension Shackle	2
803	0098353801	Bearing	4
804	0270063801	Pivot	4

PART#
7428070000
Ball Joint

PART#
6000470001
Dashpot Ass'y.

PART#
7286650000
Oiler

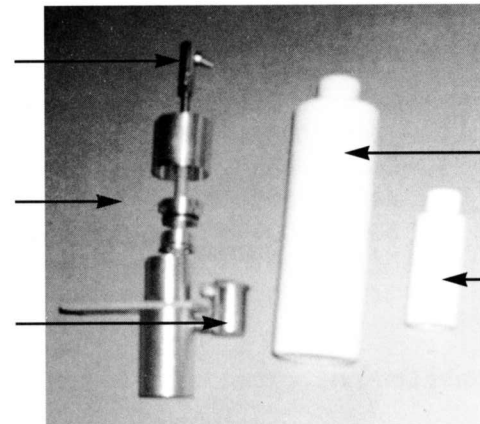

PART#
7329000002
16oz. Dashpot
Oil

PART#
7329000000*
2oz. Dashpot
Oil

GB/GBAO BELT FEEDER

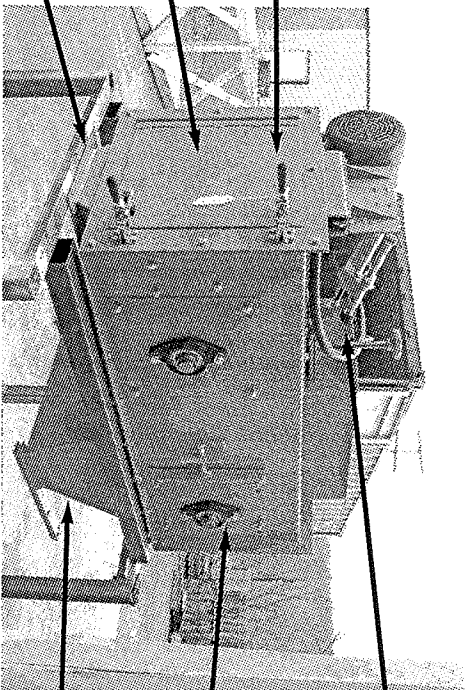

Toggle clamp
6034500000
Access door
5422120000
Chute
3600260000

Bumper
7144050000
Bearing
7623180000
Drip pan
3600170006

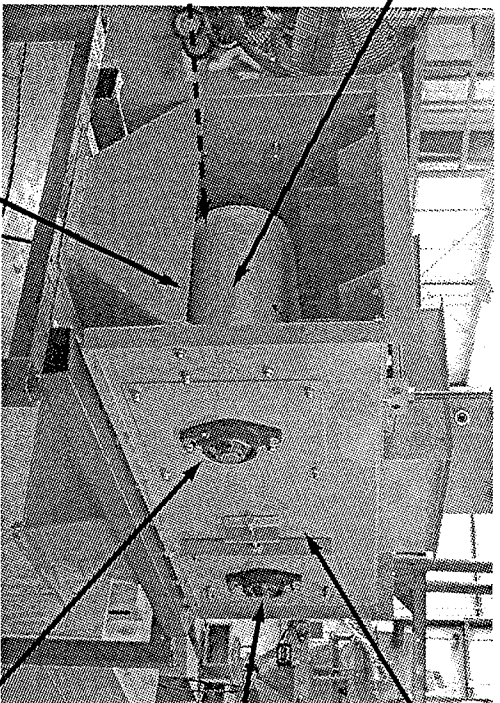

Belt
5022640000
NOT SHOWN
Scraper
3600160000
Scraper bracket
3600160001
Spring
3600080000
Belt seals
0498437801

Belt support plate
(not shown)
3600310000

Housing
3600000000
Bracket rear bearing
3600180000
Bracket front bearing
3600190000